

# Application Success Stories

## Dieteg Gerätebau GmbH & Co. KG Vehicle components



Capacity improvement

Process reliability

Coating quality

# Application Success Stories

## Installation Key Data

**Parts:** Vehicle components

**Parts size:** H 2'100 mm

W 800 mm

L 2'300 mm

**Conveyor speed:** v 1 m/min

**Scope of delivery:**

1 x MagicCompact® EquiFlow® BA04

1 x OptiFlex® Automatic AS06-12 P

12 x OptiGun® GA03-P automatic gun

1 x OptiSelect® Pro GM04 manual gun

1 x OptiCenter® All-In-One OC06 with 12 x OptiStar All-in-One® CG22-C

1 x MagicControl 4.0 (CM40 )

2 x ZA07-18 / XT10 reciprocator



# Application Success Stories

## Layout

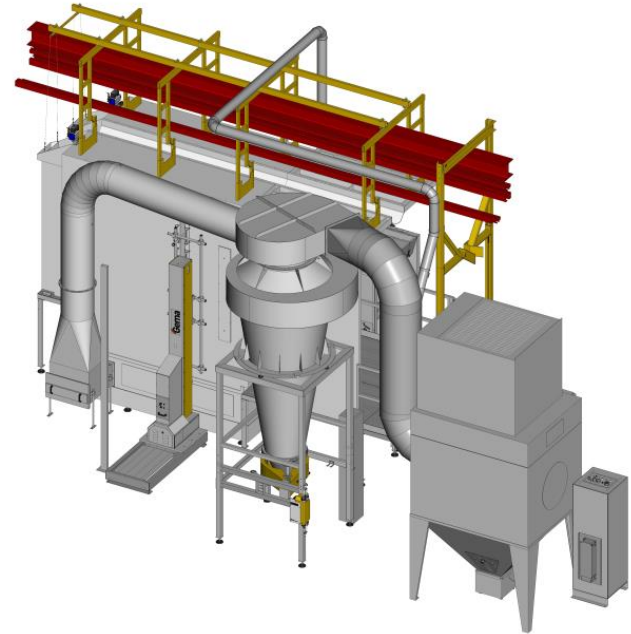
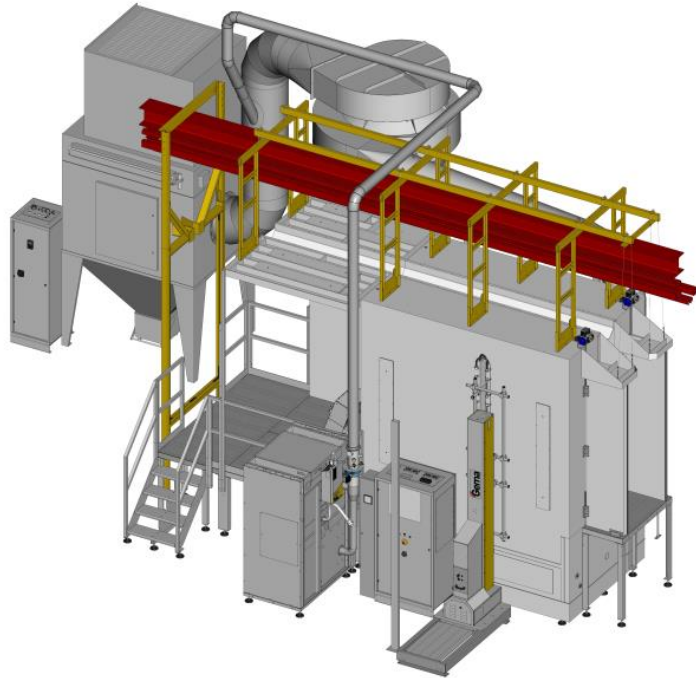

# Application Success Stories



For over 70 years, the name Dieteg has been synonymous with high-quality cabs for industrial vehicles, industrial trucks, agricultural machinery, and municipal vehicles. In the OEM and aftermarket, the company has a strong market position and, with system solutions, is an established and sought-after partner for customers all over the world.

The existing manual coating plant became uneconomical due to increasing quantities and rising quality demands. After plant inspections and successful

coating trials at Gema, Dieteg decided to install a modern MagicCompact EquiFlow quick color change system. During installation, very tight space conditions in the existing hall had to be considered and no pit could be implemented. For this reason, the system was elevated to a height of 1.35 meters. The All-In-One system from Gema provides a large precoating station where the voluminous vehicle cabins can be conveniently powder-coated.

12 automatic guns, controlled by a light grid, guarantee consistently high coating quality and thus maximum process reliability. To achieve maximum flexibility in control and workflow, the operating panel for the entire plant was mounted directly at the workspace of the coater.

Gema's system enables Dieteg to make quick and clean color changes, has provided a significant increase in capacity, standardized work processes and upgraded workplaces.