

OptiFeed BigBag (FPS16-E)

Fresh Powder Feed from the original BigBag container

The OptiFeed BigBag FPS16-E fresh powder system is designed for conveying enamel powder from large BigBag containers.

The OptiFeed 4.0 powder pump transports the powder from the original BigBag container to a distance of up to 25 meters.

Equipment technology includes:

- BigBag Lifting
- Suction unit with integrated fluidization
- OptiFeed 4.0

Key advantages of the OptiFeed 4.0 at a glance:

- Conveying of large quantities of powder across long distances and different height levels
- Gentle conveying of powder with minimal air flow
- Cleaning program in suction and conveying direction
- Wear part monitoring
- Suitable for enamel powder
- Option to connect to superior control systems
- Easy to put into operation

An electropneumatic controller uses a sensor to monitor the powder flow and control the fresh powder supply.



OptiFeed BigBag FPS16-E



OptiFeed BigBag FPS16-E with BigBag

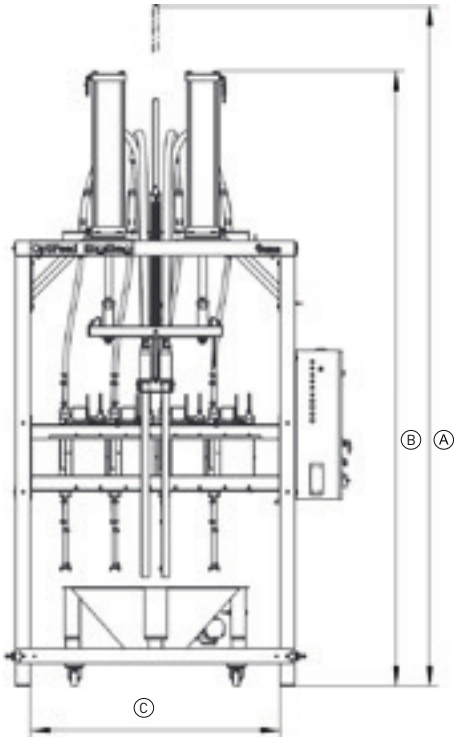

OptiFeed BigBag FPS16-E

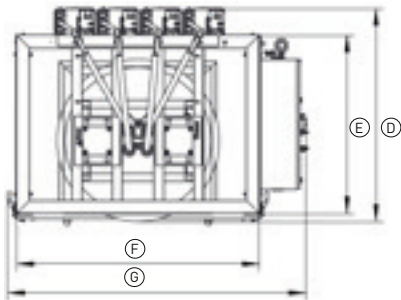

OptiFeed BigBag FPS16-E

Technical data* OptiFeed BigBag (FPS16-E)

Max. load:	1250 kg
Base area:	950 mm x 950 mm
Height:	1650 mm
Powder output:	< 8 m = 6 kg/min 8 – 16 m = 4.5 kg/min 16 – 25 m = 4 kg/min
Compressed air input pressure:	6 – 8 bar
Compressed air consumption:	12 Nm ³ /h for each OptiFeed 4.0 2.0 Nm ³ /h for lifting procedure 0.5 Nm ³ /h for the suction unit fluidization
Compressed air quality:	max. water vapor content 1.3 g/m ³ max. oil content 0.1 mg/m ³
Nominal input voltage:	3 x 400 VAC + N + PE
Frequency:	50 / 60 Hz
Input power value (connected load):	300 VA
Applicable powder:	Enamel
Safety note:	Due to accident risk and depending on the placement of the fresh powder system, the safety barriers have to be placed in accordance to the local regulations.

* The indicated conveying performance are references values. Possible deviations are dependent on the powder, powder type, conditioning and powder transportation distance.

FPS16-E			
A	3650 mm	E	1100 mm
B	3300 mm	F	1500 mm
C	1340 mm	G	1840 mm
D	1320 mm		

Configurations

The OptiFeed Big Bag (FPS16-E) can be equipped with one or max. four OptiFeed 4.0 pumps. The pumps are mounted at the back. The controls can be mounted either on the left or on the right.

Gema Switzerland reserves the right to make technical changes without notice!