

Digital Valve Technology (DVC)

Thanks to the **DVC** technology, Gema's OptiStar gun controls offer precise and reproducible powder output regulations and improve the film thickness consistency.

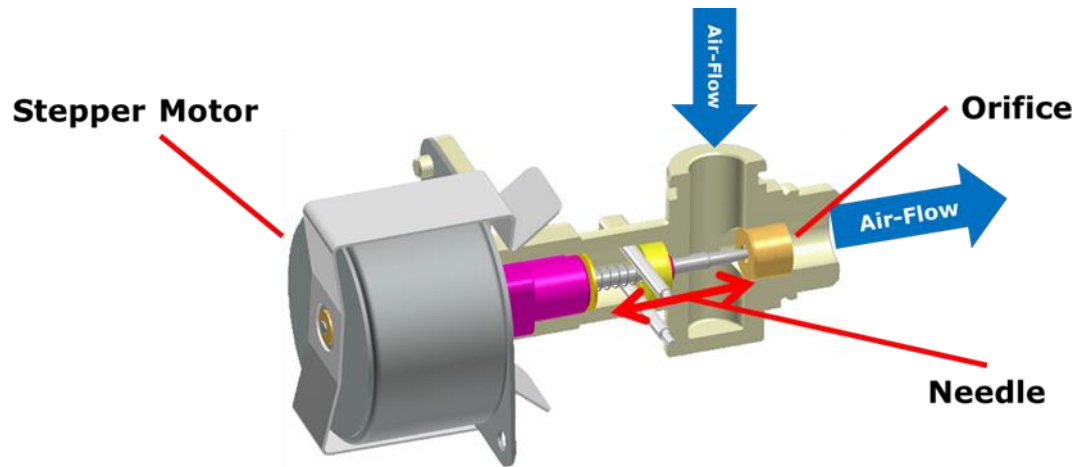

Precise
Powder Output

Powder
Savings

Reproducible
Coating Results

DVC technology: how does it work?

- **Digital Valve Control (DVC)** is the technology used in the **OptiStar** gun controls.
- The flow of compressed air to the OptiFlow injector is regulated by motor driven valves.

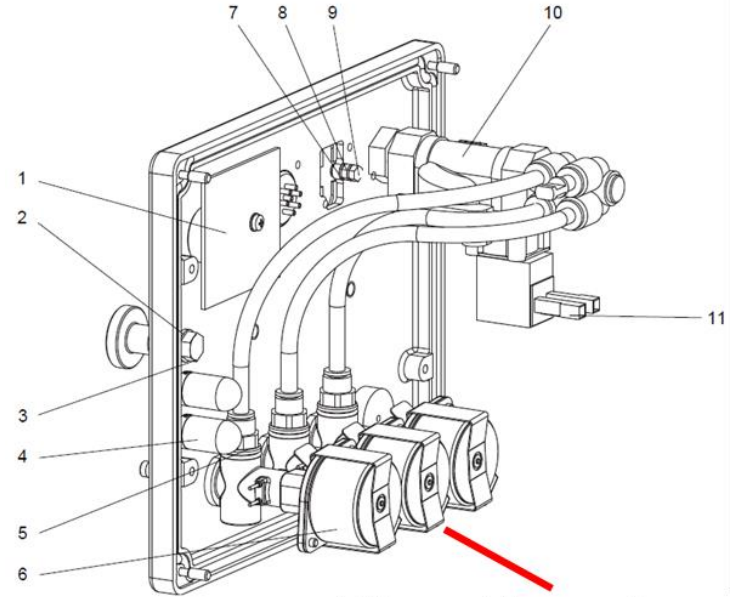

Motor-driven valves

DVC technology: how does it work?

- In each motor-driven valve a stepper motor axially moves a conical needle into an orifice and precisely regulates the size of the opening for the flow of compressed air.
- Each stepper motor position corresponds to an air-flow value and is stored by a microprocessor.
- Airflow regulations are **extremely precise** and **reproducible** with no hysteresis variations.

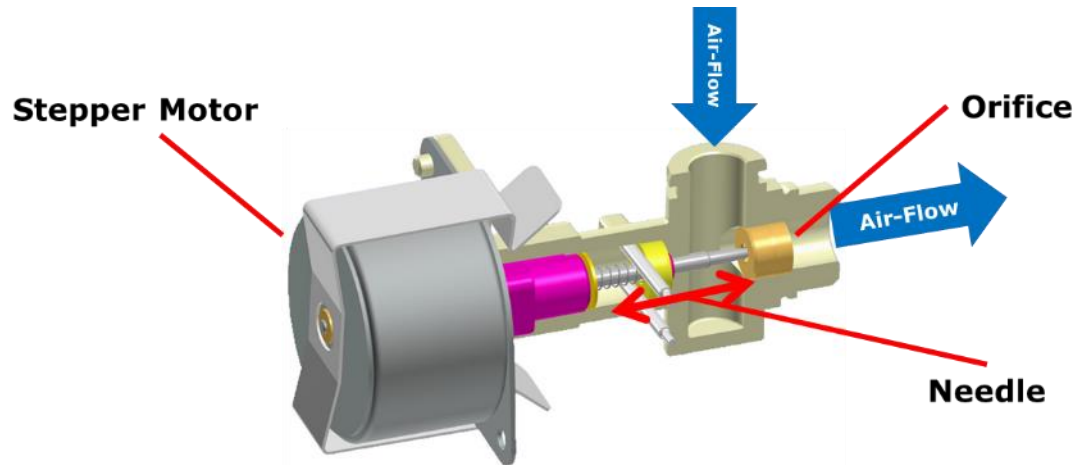

Precise Powder Output

- DVC technology allows extremely **precise powder output regulations**.
- It is very easy for every powder coater to find the right application settings for each powder / object and store them for future use.
- The control unit periodically **recalibrates** the motor-driven valves. This happens automatically, without any manual intervention.
- Powder output regulations remain **stable over time** for the best application results.

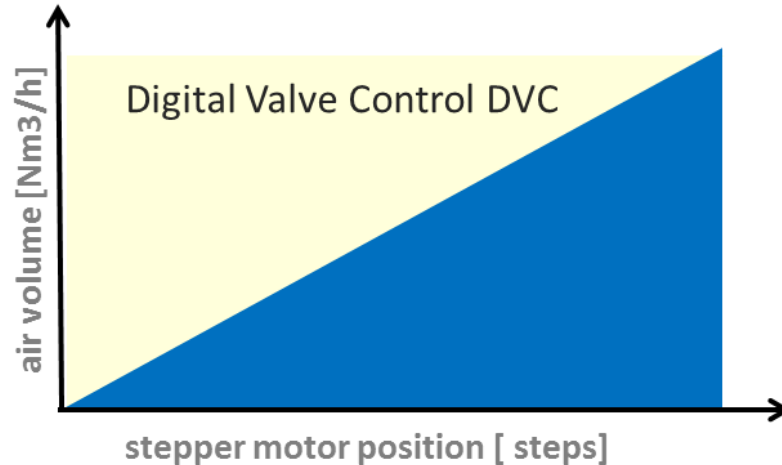

Powder Savings

- Thanks to the DVC technology it is easy to precisely regulate the powder output of **all the guns** at the same value.
- This results in a more uniform powder distribution on the surface, and consequently in very significant **powder savings**.

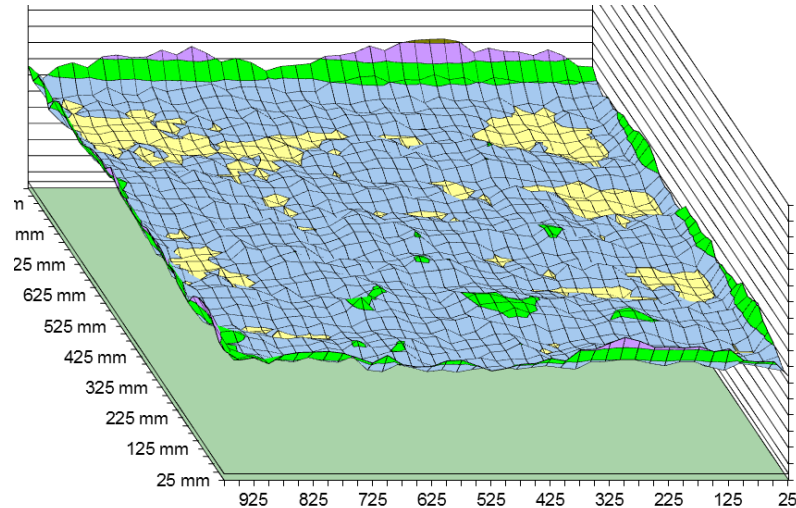

Reproducible coating results

- Thanks to their DVC technology, the motor-driven valves precisely reproduce the exact same settings for a long time, without any hysteresis problems.
- The application parameters can be easily stored in the OptiStar modules and recalled whenever needed.
- The periodic automatic recalibration of the motor driven valves ensures precise settings for the longest time.

Result:

- **Reproducible coating results are essential to achieve a consistent application quality and to save powder.**

